



RDS550

ROTARY HEAD

A hydraulic rotary head for drilling attachments and 3-6 ton drill rigs. Smooth operation and simple maintenance for general rotary drilling applications.

- Flange connection
- Lightweight, Compact
- Optional Shock Sub

RDS550 | ROTARY HEAD

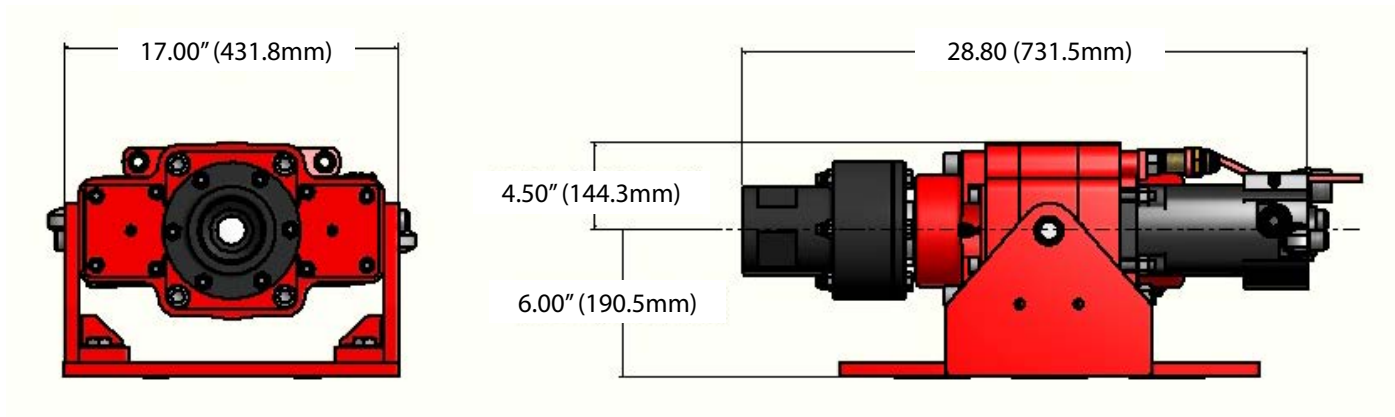

	US	METRIC
Rotation Torque	5,000 lbf·ft – 2,500 lbf·ft	6.78 kNm – 3.39 kNm
Rotation Speed	Up to 150 RPM	Up to 150 RPM
Supply Pressure	3,000 PSI	207 bar
Supply Flow	33 GPM	125 LPM
Flushing Shaft ID	1-1/2"	38 mm
Weight	237 lbs	108 kg
Max Pullback / Thrust	44,500 lbf	197 kN
Output Threads	3-1/2" API Regular Male & Female, 2-3/8" API Regular Male & Female, 1-5/8" Auger Hex, Other Threads Available	

Used on the PCF/PCFH or HCF/HCFH feed systems.
TEI technical specifications consider a 40% hydraulic power loss.

Shock Sub	RDS55199
Seal Kit	RDS5778
Overhaul Kit	